

Technical Data Bimetal Temperature Automatic Reset Type SS1U

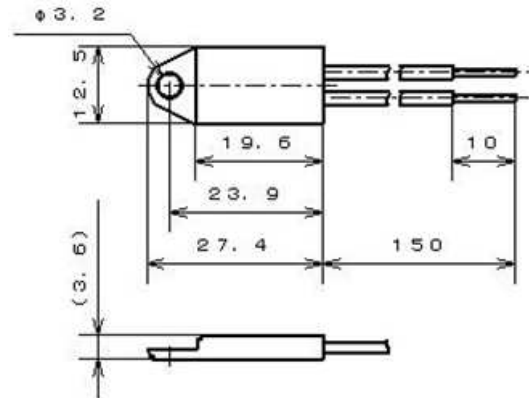

example of use



version	SS1U
contact version	automatic disconnection and connection of a circuit within the defined control range (temperature control)
contact type	NC = normally closed / NO = normally open
housing material	PBT (Polybutylene terephthalate)
nominal switching temperature	0°C until 105°C
max. ambient temperature	24h at 105°C and 24h at -30°C (according to internal test setup)
standard-tolerance range	±3K to ±4K
standard reset temperature	< 100°C differential = 10K (tolerance ±4K to ±5K) below NST > 100°C differential = 15K to 20K (tolerance ±6K to ±7K) below NST
rated voltage	230 VAC (U _N 50/60Hz)
rated current at U _N ohmic cos φ = 1,0	2A / 250 VAC for 100.000 cycles (acc. C-UL) 3A / 250 VAC for 30.000 cycles (acc. C-UL) (recommended minimum current = 100mA)
approvals	C-UL (#E201152)
connection and mounting	wire mounting bracket
high voltage insulation	2kV for 1 second
degree of protection	equivalent to IP64
contact resistance	<50mΩ

The indicated pictures, drawings and dates are exemplary. Depending on the switch configuration it may differ. Thermostats are safety components! For the use in a specific application technical guidelines, requirements or approvals must be considered and the thermostats must be tested in real environmental conditions. Please consider also the electrical power in relation with the voltage supply of your application. The approvals also differ depending on the various nominal voltage. We will be glad to help you, please ask.

Bimetal Temperature Automatic Reset Type SS1U

Functions & Types

Bimetal switch as Automatic Reset Type

After reaching its factory-adjusted **Nominal Switching Temperature (NST)** the bimetal disc suddenly turns over from its stable initial position into a stable end position and thereby activates the switching device. The electrical circuit is disconnected (NC-type) or connected (NO-type). The bimetal disc turns back automatically in its initial position to close or open the circuit again.

Normally closed (NC)

At rising temperature contacts **open** and disconnect the electric circuit. (Interruption of the signalling pathway at temporary overheating, for example temperature control of a switch cabinet)

Normally open (NO)

At rising temperature contacts **close** and activate the electric circuit. (Connection of a signal transmitter or an air cooler)

Important Information

An Automatic Reset Type is not developed for final shut down because of no permanent end switch. The listed specifications and information are based on tests and test series. They are of a standard nature and therefore deviations may occur in connection with specific applications. Please note that outside influences like moisture, gas formation, ultraviolet radiation, magnetic fields or vibrations can affect the function of the thermostat. Especially any influence of silicon must be avoided.

Benefits & Advantages

The outstanding quality level of our Automatic Reset Type SS1U satisfies highest demands for safety and reliability. They are provided with a patented, fully developed and reliable switching device system.

Standard type	height 3,6mm, length 27,4mm and whole spacing 3,2mm
Save, reliable & durable	100% tests while production process / 100% final test if required
Temperature sensitive	mechanical unstressed and electrically unloaded bimetallic disk
Fast reaction	excellent heat transfer induced by an ideal placed bimetallic disk
Flexible use	specific customer requests

The manufacturing and production of our Thermostats is DIN ISO 9001 certified and of course the current RoHS-conformity is complied.

Our friendly team will give you detailed information of all our products. Of course, we want to help you, to find the best solution for your application. Please call us for further information.

Protherm Wärmeschutz GmbH
Turnstraße 28
D-75328 Schömberg

Phone: +49 (0) 7235 980 200
Fax: +49 (0) 7235 980 201
E-mail: kontakt@protherm.info
Internet: www.protherm.info